

High-Speed Response Non-Isolated POL DC-DC Converter

Bellnix®

BSV-H Series

BSV-H Series is a small (27.0x16.5x4.0mm), light (2.8g), 52.8W output power step-down DC-DC converter. With ultra-low output voltage from 0.8V, it can support the latest DSP, ASIC applications. High efficiency and ultra-high-speed response with synchronous rectification have been achieved along with space-saving SMD packaging without external parts. This product will exceed your expectations in all aspects.



■ Features

- Output Voltage Accuracy $\pm 1.0\%$
- Ultra-high Efficiency 92%
- Ultra Compact, High Power Density
- Non-isolated type Converter
- Built-in Over Current Protection Circuit
- ON/OFF Control
- High-speed Response
- External Capacitor Not Required
- Heat Sink Not Required
- Adjustable Output Voltage
- Operating Temp Range -40°C to $+85^{\circ}\text{C}$
- High Reliability, High Performance
- Use of the Latest Power-IC
- Synchronous rectification
- RoHS Compliant
- Short-circuit, Over Current Protection Circuit
- SMD Package

■ Model/Rating

Table 1

Models BSV Series	Input V Vdc	Output V Vdc	Output I A	Line Reg. %(typ.)	Load Reg. %(typ.)	Ripple Noise mVpp(typ.)	Efficiency %(typ.)
BSV-3.3S16R0H	5.0V (3.0 to 5.5)	3.3V (0.8 to 3.3)	0 to 16	0.5	0.5	30	92

Note 1: Unless otherwise specified, measured at input voltage 5.0V, output voltage 3.3V, output current 16A and ambient temperature $25^{\circ}\text{C}\pm 5^{\circ}\text{C}$.

Note 2: Efficiency is measured at input voltage 5.0V, output voltage 3.3V, output current 16A and ambient temperature $25^{\circ}\text{C}\pm 5^{\circ}\text{C}$.

Note 3: Potential difference of 0.7V or more is required between input voltage and output voltage. $V_{in}(V)-V_{o}(V) \geq 0.7V$

Note 4: Ripple noise is measured at 20MHz bandwidth.

Note 5: Depending on the ambient temp. conditions, output derating and air flow cooling may be required.

■ Specifications

Table 2

Input voltage range	Refer to Table 1
Rated input voltage	5.0V
Rated output voltage	3.3V
Output voltage initial setting	3.3V (When Trim pin is open)
Adjustable output voltage range	Refer to Table 1
Output voltage accuracy	$\pm 1.0\%$ ($\pm 0.033V$)
Line regulation	Refer to Table 1 (Rated output, input voltage varying in the range of Table 1)
Load regulation	Refer to Table 1 (Rated input/output voltage, load varying from 0 to 100%)
Temp. regulation	$\pm 0.02\%/^{\circ}\text{C}$ typ. (5V input, 3.3V, 12A output, operating temp varying from -40°C to $+55^{\circ}\text{C}$)
Ripple noise	Refer to Table 1 (Rated input/output, measurement frequency bandwidth 20MHz)
Efficiency	92% typ. (Rated input/output, refer to Table 1)
Turn-on Rise time	1.0ms typ. (Resistance load)
Max. output load capacity	10000 μF max.
Over current protection	Yes
Output over voltage protection	None
Remote ON/OFF control	Yes
P-Good output	Yes
Remote sensing	Yes
Operating temp range	Operating temperatures -40°C to $+85^{\circ}\text{C}$ (Refer to temp derating described separately)
Storage temp range	Storage temperatures -40°C to $+85^{\circ}\text{C}$
Humidity range	20% to 95% R.H. (Max. wet bulb temp 35°C with no condensation)
Storage conditions	Below $30^{\circ}\text{C}/60\%$ R.H. before mounting the converter
Cooling conditions	Refer to temp derating shown separately
Vibration	5 to 10Hz total amplitude 10mm (3 directions, 1 hour each), 10 to 55Hz acceleration 2G (3 directions, 1 hour each)
Impact	Acceleration 20G (3 times for each of 3 directions), Impact time $11\pm 5\text{ms}$
Weight	2.8g typ.
Outer dimensions	W=27.0 L=16.5 H=4.0 (mm) (For dimensional details, refer to the shape and dimensions shown separately)

* The above specifications are provided with rated value, unless otherwise specified.

* The contents provided in this datasheet may be changed at any time without prior notice.

High-Speed Response Non-Isolated POL DC-DC Converter

Bellnix® **BSV-H Series**

1. Scope

These specifications shall apply to the DC input, non-isolated type DC-DC converter BSV-3.3S16R0H.

2. Model/Rating

Model name	Rated input voltage	Rated output	Shape	Remarks
BSV-3.3S16R0H	DC5.0V	3.3V, 16.0A	SMD	

Unless otherwise mentioned in these specifications, input shall be rated input, output shall be rated output, and ambient temperature shall be 25°C±5°C.

3. Environmental conditions

3-1 Temperature range

In operation -40°C to +85°C (Derating required)
 In storage -40°C to +85°C

3-2 Humidity range

In operation 20 to 95% R.H. (However, max. wet bulb temperature 35°C, no condensation)
 In storage 20 to 95% R.H. (However, max. wet bulb temperature 35°C, no condensation)

Note) For storage before mounting, store in a place below 30°C and 60% R.H.

4. Specifications & Standards

This product is lead free.

4-1 Input characteristics

Item	Specifications & Standards	Conditions
Input voltage	+3.0 to 5.5V (Rating 5.0V) *1	
Input current	11.52A typ.	Upon rated input and rated output
Standby current	1.0mA max.	Vin=5.0V, when short-circuiting On/Off pin and GND

*1 Input voltage to be set higher than output voltage by 0.7V or more.
 (Vin ≥ 4.0V when Vout=3.3V)

4-2 Output characteristics and functions

*2, *3

Item	Specifications & Standards	Conditions
Rated output voltage	3.3V	
Output voltage accuracy	3.3V±1% (±0.033V)	
Adjustable output voltage range	0.8V to 3.3V	By external resistor
Output current	0 to 16A	Derating required
Line regulation	0.5% typ. 1.0% max.	Input voltage varying from 4.0 to 5.5V
Load regulation	0.5% typ. 1.0% max.	Load varying from 0 to 16A
Temperature regulation	±0.02%/°C typ.	Upon 12A output. Temperature varying from -40 to +55 °C
Efficiency	92% typ.	Upon output of 16A
Ripple noise	30mVp-p typ. 100mVp-p max.	BW=20MHz
Over current protection circuit	Operate at 105% or above, auto restart type	
Over voltage protection circuit	None	
Under voltage lock out	Yes Activation voltage: 2.84V±0.1V Deactivation voltage: 2.78V±0.1V	
ON/OFF control	ON when open (2.6V or more) OFF when short (0.65V or less)	Upon input of 3.3V
	ON when open (3.75V or more) OFF when short (0.9V or less)	Upon input of 5.0V
P-Good threshold voltage	±72mV (58 to 86mV)	When Vout < 1.2V
	±6.1% (4.8 to 7.1%)	When Vout ≥ 1.2V
P-Good low level voltage	0.3V max.	Sink current 4mA max.
Turn-on Delay	Upon activation by input voltage: 1.8 to 2.8ms	
	Upon activation by On/Off pin: 40 to 100µs	
Turn-on Rise	1.0ms typ.	Resistance load
P-Good blanking time	4.0ms typ.	Upon activation only
Max. output capacitive load	10000µF max.	

*2 With the measurement circuit of 4-3.

*3 Unless otherwise specified, measured at 5.0V input voltage, 3.3V output voltage, 16A output current, and 25°C±5°C ambient temperature.

4-3 Measurement circuit

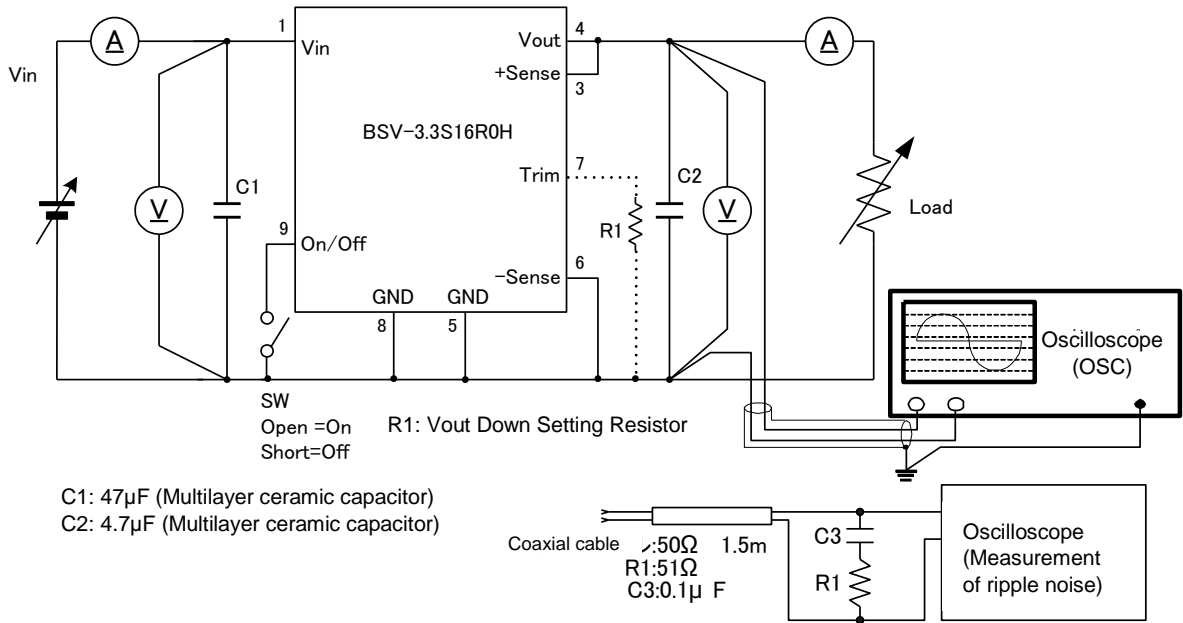

5. Block diagram

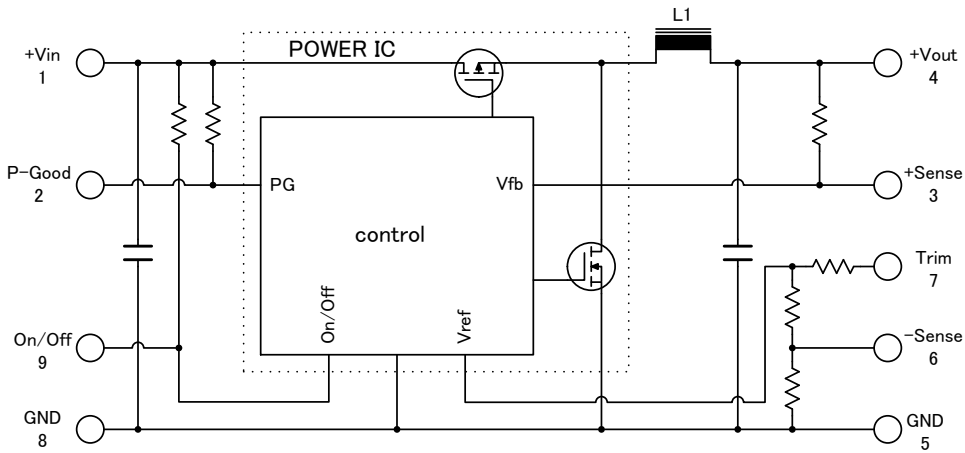

6. Temperature derating

The product requires placement on PCB with good airflow due to a design to release heat through the PCB. The lines to the converter should be taken thick and wide, especially lines to the GND pin, for it has a large heat release.

The derating curve below is when mounted onto the double-sided board of copper coating thickness 35µm, copper coating dimension 100mm x 100mm (both sides) and PCB thickness 1.6mm. Please use it as a reference because the heat release characteristics may change depending on wiring.

Since the temperature characteristics are largely affected by PCB and the ambient temperature, it is important to make sure that the IC (refer to the outer dimensions) surface temperature of the converter does not exceed 120°C when operated at the max ambient temperature in an actual device.

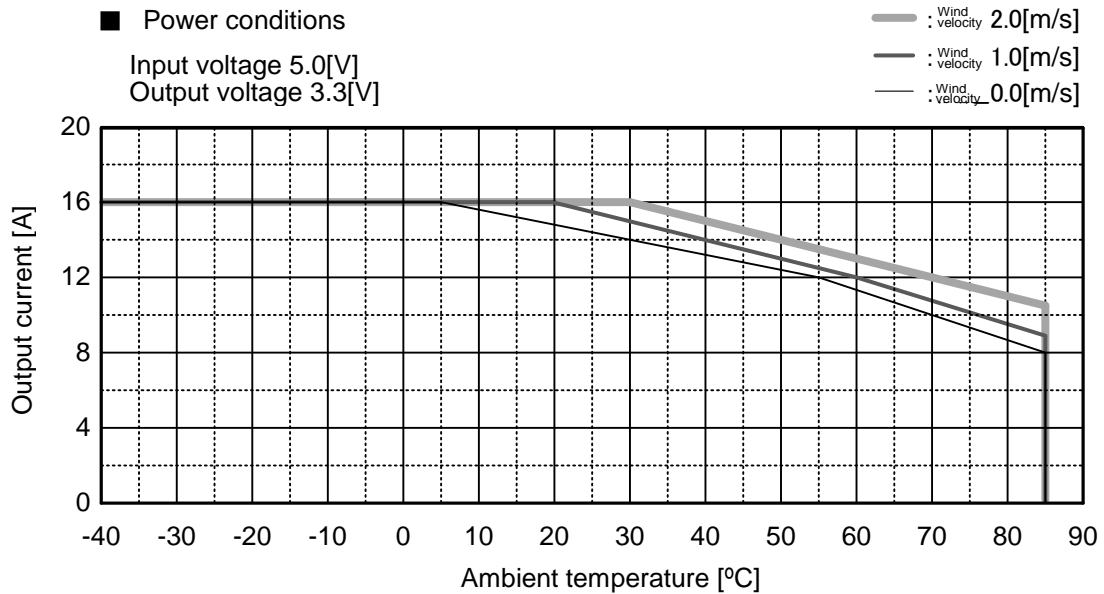

7. Outer dimensions and description of pins

7-1 Shape and dimensions (SMD type)

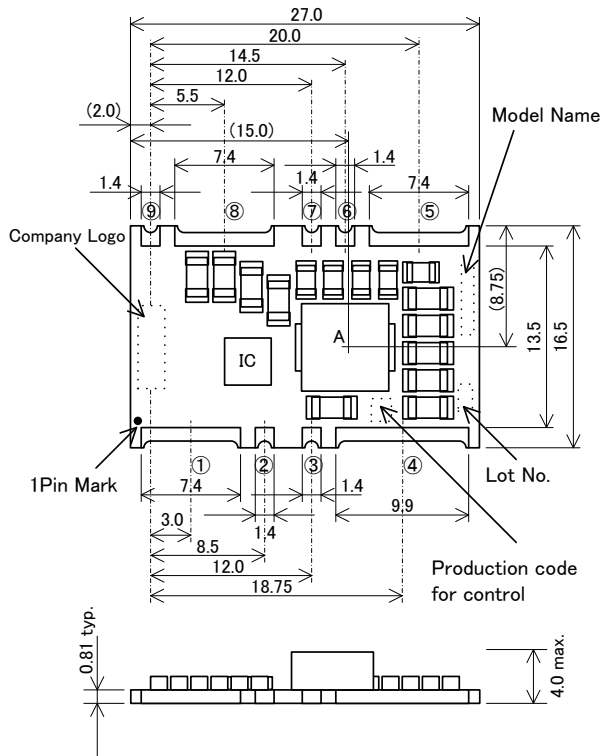

Pin	Function
1	+Vin
2	P-Good
3	+Sense
4	+Vout
5	GND
6	-Sense
7	Trim
8	GND
9	On/Off

- Unit: mm
- Dimensional tolerance (unless specified) ± 0.5
- Weight = 2.8g typ.
- Pickup point is shown as A in the drawing on the left
- Lot No. display: (1)(2)(3)
 - (1) The last digit of A.D.
 - (2) Manufacturing month (Oct/Nov/Dec = O/N/D)
 - (3) Production code (may not be indicated)
- Pin's variation is 0.2 mm max. (when placed on the level).

Note) Make sure to use the pickup point A as indicated in the drawing on the left during auto-mounting. Picking up at IC has to be avoided.

7-2 Recommended footprint dimensions

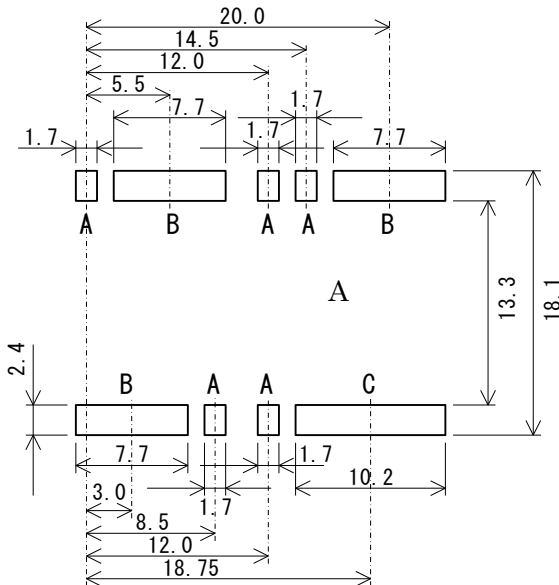

Note) Avoid wiring patterns directly underneath the converter (the first layer). Since this product uses a standard through-hole board, a pinhole on the resist may cause problems.

Note) Recommended dimensions are shown above. Use your design standard for your specific design.

8. Usage information

8-1 Standard connection diagram

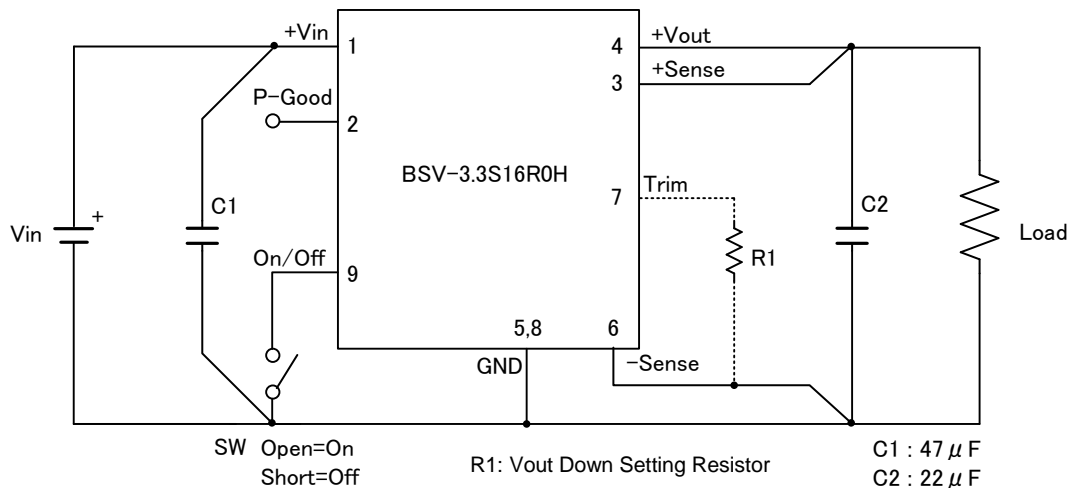

Note 1: The product requires that it be mounted on the PCB since more than 70% of the heat is released through GND pins (5, 8pin) and the rest through +Vin pin and +Vout pin. The patterns should be taken wide enough to release heat when designing.

Note 2: Keep ON/OFF pin open when not using ON/OFF control.

Note 3: Keep Trim pin open when not using adjustable output.

Note 4: GND pins (5, 8pin) are connected internally. These two pins should be connected to GND line to make the best use of the product.

Note 5: Make sure that Sense pin is connected on the board. No connection of Sense pin may result in the voltage output being higher than rated voltage.

Note 6: Avoid wiring patterns directly underneath this product (the first layer). This shall not apply to any area other than the surface layer on the converter side.

Recommended capacitor

C1 = 47 μ F

C2 = 2.2 μ F to 200 μ F typ. 10000 μ F max.

C1: Not required as long as impedance is very low and lines between +Vin side and the converter are connected thick and short. For high impedance, adding a capacitor of low ESR such as an organic semiconductor solid capacitor or a multi-layered ceramic capacitor is recommended.

C2: Not required due to an internal output capacitor. A multi-layered ceramic capacitor placed on the load side will be recommended to satisfy electrical characteristics (to reduce ripple noise).

8-2 Turn-on Rise characteristics

Amount of start-up time required for activating output voltage and P-Good signal after meeting start-up conditions shall be as illustrated in the following figure.

Note 1) Apply V_{in} of the converter at the speed faster than 5V/s.

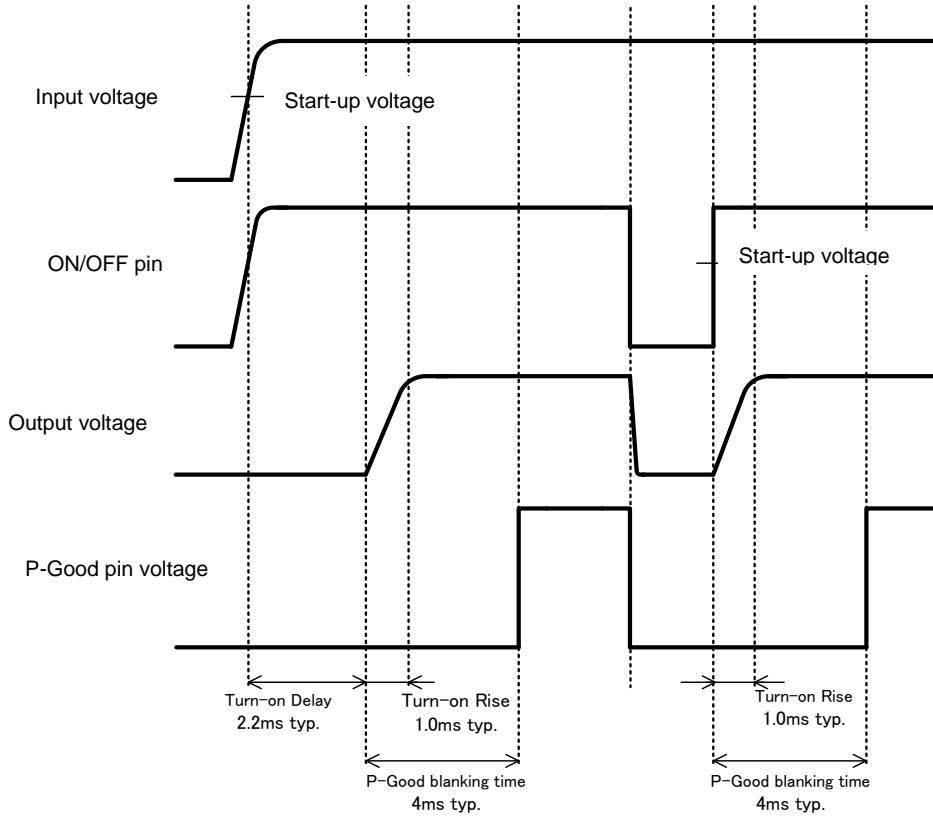

* In the measurement circuit of 4-3

8-3 ON/OFF Control

The ON/OFF Control function enables users to control ON/OFF of the output voltage without inputting or cutting it off. On/Off pins are connected inside to +Vin pin with a 22kΩ resistor.

Leave the On/Off pin open when ON/OFF Control is not used.

Between On/Off pin (No.9 pin) and GND (No.8 pin)

- | | | |
|-------------------------------|-----|------------|
| Open | ... | Output ON |
| Short (0 to 0.65V 0.3mA max.) | ... | Output OFF |

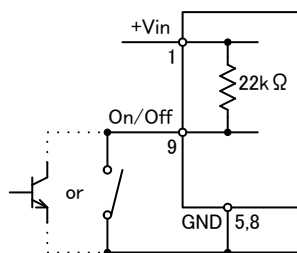

8-4 Adjustable method for output voltage

Keep Trim pin (7pin) OPEN, when using output voltage at 3.3V without adjustment. Output voltage may be adjusted between 0.8 and 3.3V by connecting a resistor between Trim pin (7pin) and -Sense pin (6pin). Connect -Sense pin to GND (5pin).

Wiring for Trim pin should be short and straight preferably when using adjustable output voltage feature. If noise appears on the pin, it causes mal-function.

The below formula should be referred for external resistance. It is important to check output voltage and adjust resistance in an actual device.

When setting output voltage between 0.8V and 3.3V

$$R_x = \frac{R_2 \times R_4 \times V_{out}}{(R_1 + R_2) \times R_4 \times I_1 - R_2 \times V_{out}} - R_3 \quad (\Omega)$$

R1=51Ω, R2=182Ω, R3=24kΩ, R4=94.3kΩ, I1=0.02733mA, Vout=Desired output voltage (V)

e.g.

Desired output voltage (V)	Rx calculated value (kΩ)
3.3	OPEN
2.5	271.0(270+1)
2.0	121.1(120+1.1)
1.8	89.5(82+7.5)
1.5	54.6(51+3.6)
1.2	30.0
1.0	17.0(15+2)
0.8	6.2

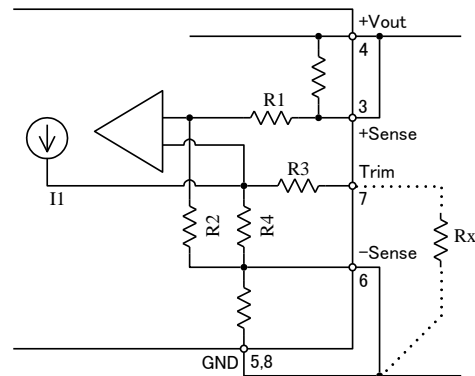

8-5 Sensing pin

Sensing function provides good load fluctuation characteristics on the board. Sensing line constitutes a part of a feedback loop and is very sensitive, so careful wiring is required. +Sense pin and -Sense pin should be connected close to each other on the board.

When sensing function is not used, always make sure of the respective pin connections on the board between +Vout and +Sense and between -Vout and -Sense.

8-6 P-Good pin

Output state of the converter may be obtained by using P-Good pin. This pin is pulled up internally to +Vin pin with 47kΩ resistor. When output voltage (+Sense pin voltage) goes out of the converter's pre-set range, P-Good pin becomes low.

- $V_{out} < 1.2V$: | Output voltage-Set voltage | $\leq 72mV$ typ. -> High
- $V_{out} \geq 1.2V$: | Output voltage-Set voltage | $\leq 6.1\%$ typ. of set voltage -> High

However, even if the above conditions are fulfilled, output voltage may decrease to Low under the following circumstances.

- Potential difference between input and output: $V_{in} - V_{out} < 0.7$
- Input voltage less than 3V
- Output current in over current state
- IC's junction temp exceeding 150°C typ.

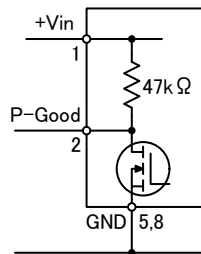

9. Protection against reverse connection for input power supply (example)

This product is a DC-DC converter with non-isolation between input and output to have a positive polarity step down to a positive polarity. This product will be damaged if erroneously connected with reverse input polarity. To cope with possible reverse connection, add a protection circuit as shown in the following figure.

The following is an example using a fuse and a diode.

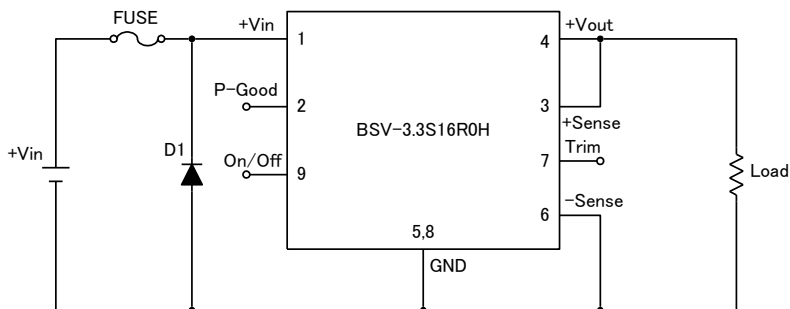

10. Over voltage protection circuit (example)

This product has no built-in function for over voltage protection.

If the product is damaged for any reason, DC input voltage will be output as is. To prepare for the damage by over voltage mode, add an input cutoff circuit as shown in the following figure.

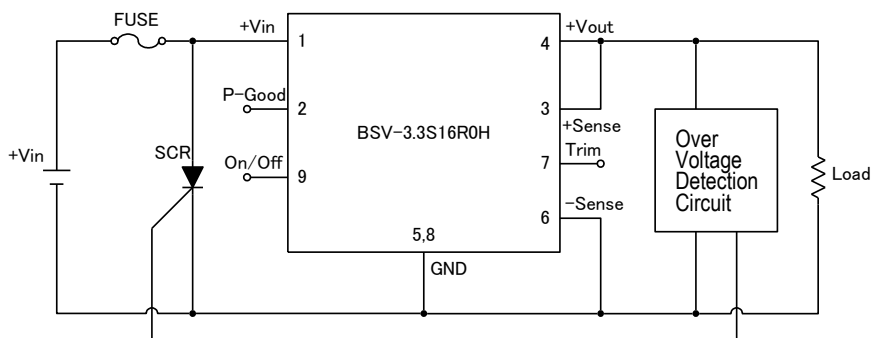

Note 1: ON/OFF control does not function in case of overvoltage mode damage.

Note 2: ON/OFF function on the power supply side can be used, if any.

Note 3: Allow enough capacity for DC power supply for a fuse to blow.

11. Mounting conditions

Observe the following conditions for soldering temperature and time as well as for the storage before mounting.

Flow mounting is not possible for this product.

11-1 Reflow method

Preheat temperature: 150 to 180°C, 60sec. max. (Refer to the figure below.)

Peak temperature : 250°C max.
220°C or higher 60sec. max.

Number of reflows : Twice

Note 1) Refrain from giving vibration during the reflow, for it may cause converter components to move.

Note 2) After mounting the converter onto the board, reflow cannot be made again by turning over the mounted board.

11-2 Storage before mounting

The humidity control level for this product is MSL3. For storage before mounting, if a dry pack is opened, store at an ambience of 30°C/60% R.H. or below. If the dry pack storage exceeds one year or the storage of an opened dry pack at 30°C/60% R.H. exceeds 168 hours, baking (125°C±5°C, 12H) is required before the reflow process.

Storage condition will govern after mounting.

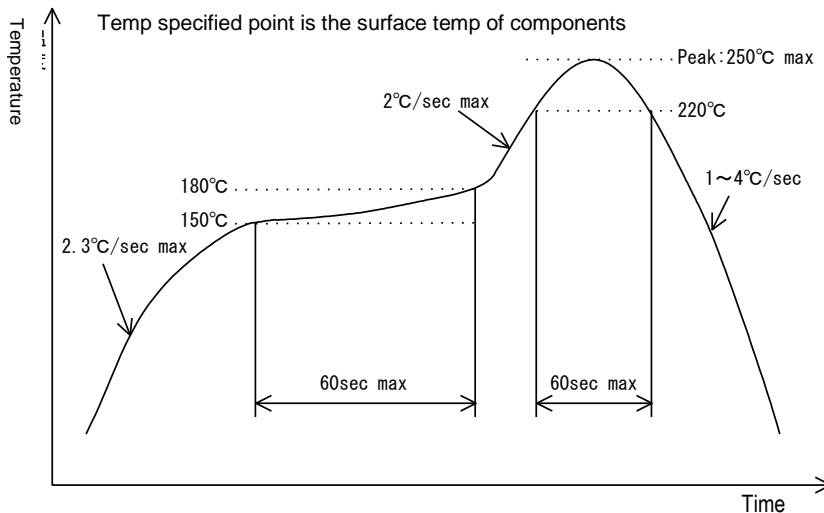

12. Vibration and impact tests

Vibration: 5 to 10Hz Total amplitude 10mm, 10 to 55Hz Acceleration 2G (3 directions, 1 hour each)

Impact : Acceleration 20G (3 directions, 3 times each)
Duration 11±5ms

13. Cleaning

This product is not for immersible cleaning. Use of no-clean flux is recommended.

14. Precautions for use

To ensure user's safety, check specifications before using the product and always observe the following precautions for use.

- This product is intended for use in general electronics equipment (office equipment, communication equipment, measurement equipment). Do not use the product for medical equipment, nuclear equipment, trains, etc., whereby human life or property may be directly affected by damaged product. Consult with us for any use other than for such general electronics equipment.
- This product is not suitable for serial or parallel operation.
- Do not use connectors and sockets for mounting the product. Contact resistance may have an adverse effect on the performance. Use the soldering method for mounting on the printed circuit board.
- This equipment has a built-in over current protection circuit but avoid a prolonged short circuit which may lead to failure.
- This product may be damaged if used under nonstandard electrical conditions or nonstandard environmental conditions including temperature. Ensure use within the standards.
- Avoid using this product in a place that generates corrosive gas or is dusty.
- This product may be damaged by static electricity. Make sure that the workplace is guarded against static buildup and static electricity on operators by use of proper grounding.
- A fuse mechanism is not built in this product. Connect a fuse to +input line to guard against excessive input current under abnormal circumstances. Allow enough capacity for power supply for a fuse to blow.
- This product has no build-in function for over voltage protection. If over voltage occurs due to anomalies in the module, input voltage is output, as is, in the same mode, which may result in fumes and ignition. To prevent this from occurring, always add an over voltage protection circuit.
- This product does not come with a test report.

15. Warranty

The warranty term of the product is one year after shipment. Should the product become defective within the warranty period due to our design or workmanship, the product will be repaired free of charge or replaced.

However, this warranty does not cover products which have been subjected to unauthorized inner modifications, etc.

The scope of our warranty is limited to that of the said product.

16. Miscellaneous matters

Any doubt arising out of or in connection with these specifications shall be determined upon mutual consultation between the parties concerned.

17. Contact

If you have any further technical questions for this product, please contact us.

E-mail: info@bellnix.com

URL: <http://www.bellnix.com>